

Lining plate

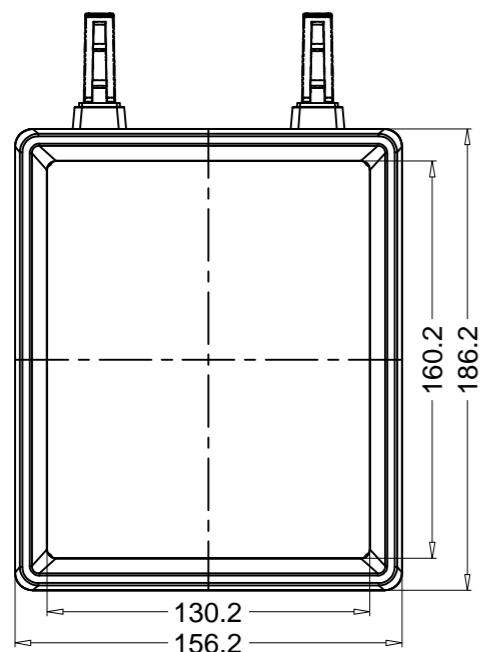

G VIEW

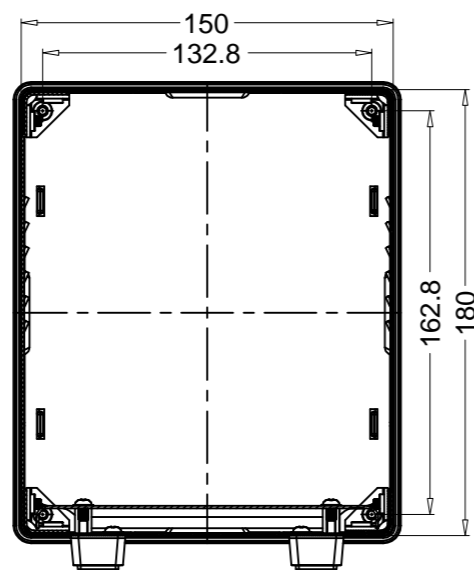

SEC A-A

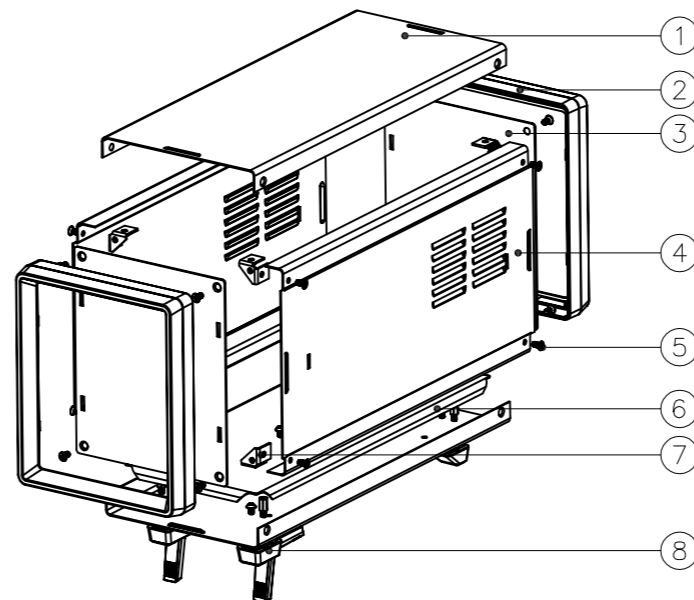

8	Tripod	ABS	1	CJ-22	
7	Bracket	STD	8	40017-F1	
6	Lining plate	AL	1	40018-C2	1.5mm
5	Screws	STD	16	KM4x8	
4	Side plate	SECC	1+1	40018-A2	1.0mm
3	baffle	AL	2	40018-D1	1.5mm
2	panel	ABS	2	40018-E1	
1	Upper and lower plates	SECC	1+1	40018-B2	1.0mm
Drawing	Auditing	Confirm	Product Name	Iron case	Project View
			Product Type	BDA 40018 W350	Drawing Scale
					1:1 (MM)