

产品型号(MODEL NO.): BWP 10601-A1

产品尺寸 ( SIZE ): 250×175×100MM

产品重量(WEIGHT):

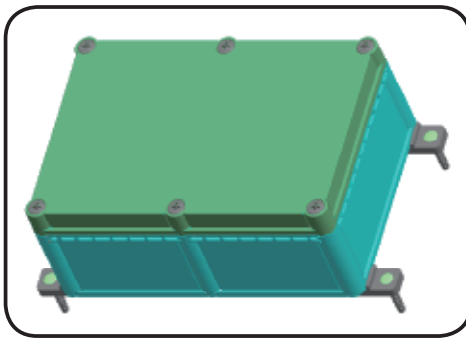

11226000

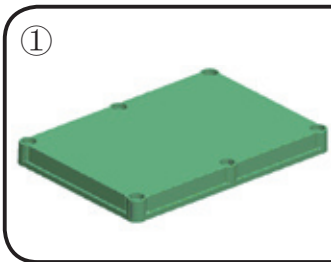
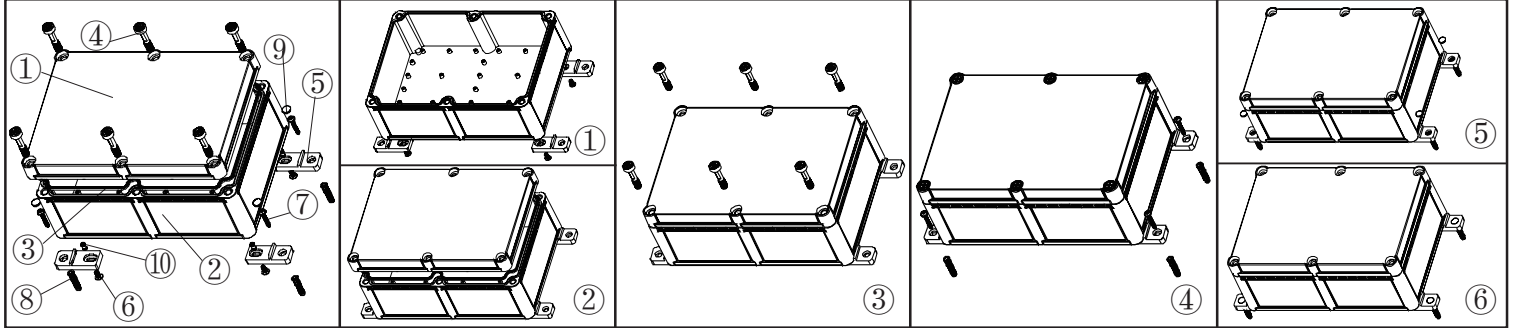

产品编号(NUMBER):10601-B1  
产品名称(NAME):上壳 EPIVALVE  
模具编号 (P/NO):BAH10052-A1  
材料(MATERIAL):ABS(LIGHT GREY:FS20412)  
用量(QUANTITY):1 PCS  
重量(WEIGHT):

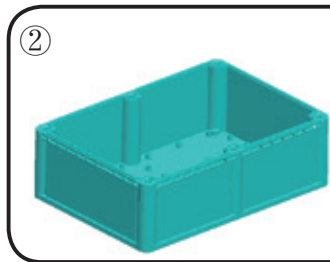

产品编号(NUMBER): 10601-C1  
产品名称(NAME):下壳 HYPOTHECA  
模具编号(P/NO): BAH10052-A2  
材料(MATERIAL):ABS(LIGHT GREY:FS20412)  
用量(QUANTITY): 1 PCS  
重量(WEIGHT):

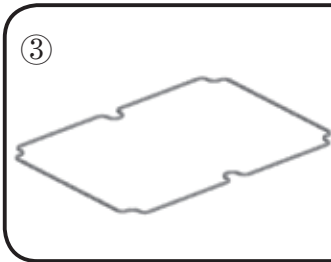

产品编号(NUMBER): 10601-D1  
产品名称(NAME): 防水圈GASKET  
材料 (MATERIAL): 橡胶RUBBER  
用量(QUANTITY): 1 PCS  
尺寸 (SIZE): 96.5x64.5x1.8 MM  
重量(WEIGHT):

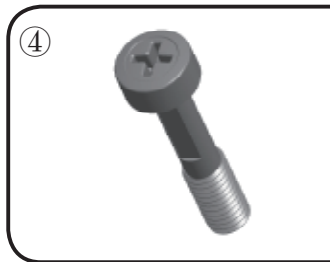

产品编号(NUMBER): 10601-E1  
产品名称(NAME): 螺丝 SCREW  
模具编号(P/NO): BAH10027-A4  
规格(STANDARD):  
材料(MATERIAL): PC  
用量(QUANTITY): 6 PCS

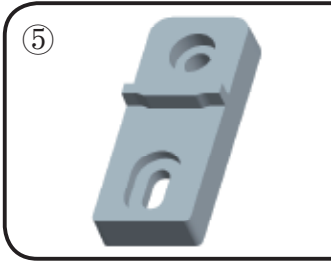

产品编号(NUMBER):10601-F1  
产品名称(NAME): 墙挂WALL TIE ACCESSORIES  
模具编号 (P/NO):BAH10027-A3  
材料(MATERIAL):ABS(LIGHT GREY:FS20412)  
用量(QUANTITY): 4 PCS

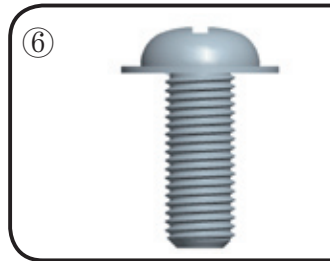

产品编号(NUMBER):PWM4×10  
产品名称(NAME):螺丝 SCREW  
规格(STANDARD):M4×10  
材料(MATERIAL):STAINLESS STEEL  
用量 (QUANTITY):4 PCS

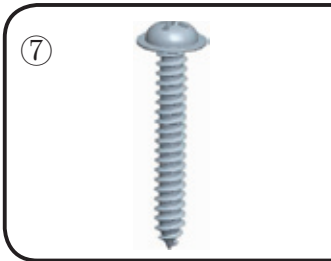

产品编号(NUMBER):PWA4×30  
产品名称(NAME):自攻螺丝SELF-TAPPING SCREW  
规格(STANDARD):M4×30  
材料(MATERIAL):铁 IRON  
用量(QUANTITY): 4 PCS



产品编号(NUMBER): S-6  
产品名称(NAME): 墙钉 WALL NAIL  
模具编号(P/NO): BAH10032-A1A2  
规格(STANDARD): S×6 φ4-5  
材料(MATERIAL): PP(GREY:CM906)  
用量(QUANTITY): 4 PCS

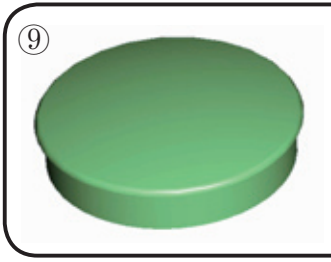

产品编号(NUMBER):KN-500-B1  
产品名称(NAME): 螺丝盖 SCREVLID  
模具编号(P/NO): BAH10001-A3  
材料(MATERIAL): ABS(LIGHT GREY:FS20412)  
用量(QUANTITY): 4 PCS

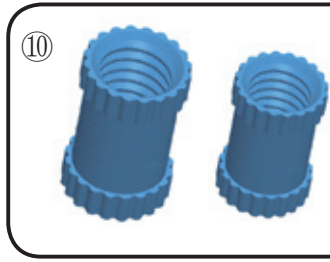

产品编号(NUMBER): M4×8 / M4×6  
产品名称(NAME): 铜套 COPPER NUT  
规格(STANDARD): M4×8 /M4×6  
材料(MATERIAL): 铜 COPPER  
用量(QUANTITY): 4 PCS/6PCS  
颜色 (COLOR): 铜色 COPPER

名称 NAME	尺寸 SIZE (MM)	CARTON No.	G . W (KG)	N . W (KG)	每箱数量 QUANTITY	PE袋 POLYBAG
小箱 SAMLL CARTON						
大箱 BIG CARTON						